



User Guide

BT914 Amplified Big Button Cordless Phone with Bluetooth® Connectivity



IMPORTANT SAFETY INSTRUCTIONS

Congratulations on purchasing your new Clarity product. Before using this telephone, please read **Important Safety Instructions**.

WARNINGS: PRIVACY OF COMMUNICATIONS MAY NOT BE ENSURED WHEN USING THIS PHONE.

To maintain the compliance with the FCC's RF exposure guideline, place the base unit at least 20 cm from nearby persons. To reduce the risk of fire or injury to persons, read and follow these instructions.

1. Read and understand all instructions.
2. Follow all warnings and instructions marked on the telephone.
3. Avoid contact with liquids. Do not locate base unit or handset near water, for example, near a bathtub, wash basin, sink or laundry tub, in a wet basement or near a swimming pool.
4. Avoid using a telephone (other than a cordless type) during a storm. There may be a remote risk of electrical shock from lightning.
5. Do not use the telephone to report a gas leak in the vicinity of the leak.

IMPORTANT SAFETY INSTRUCTIONS

6. Unplug this telephone from the wall outlets before cleaning. Do not use liquid cleaners or aerosol cleaners on the telephone. Use a damp cloth for cleaning.
7. Place this telephone on a stable surface. Serious damage and/or injury may result if the telephone falls.
8. Do not cover the slots and openings on this telephone. This telephone should never be placed near or over a radiator or heat register. This telephone should not be placed in a built-in installation unless proper ventilation is provided.
9. Operate this telephone using the electrical voltage as stated on the base unit or the owner's manual. If you are not sure of the voltage in your home, consult your dealer or local power company.
10. Do not allow anything to rest on the power cord or locate this product in an area where the power cord is likely to be damaged by furniture or foot traffic.
11. Do not overload wall outlets or extension cords as this can increase the risk of fire or electrical shock.
12. Never push any objects through the slots in the telephone. They can touch dangerous voltage points or short out parts that could result in a risk of fire or electrical shock. Never spill liquid of any kind on the telephone.

IMPORTANT SAFETY INSTRUCTIONS

13. To reduce the risk of electrical shock, do not take this phone apart. Opening or removing covers may expose you to dangerous voltages or other risks. Incorrect reassembly can cause electric shock when the appliance is subsequently used.
14. Unplug this product from the wall outlet and refer servicing to the manufacturer under the following conditions: when the power supply cord or plug is frayed or damaged; if liquid has been spilled into the product; if the telephone has been exposed to rain or water; if the telephone has been dropped or the case has been damaged; if the telephone exhibits a distinct change in performance; if the telephone does not operate normally by following the operating instructions. Adjust only those controls that are covered by the operating instructions. Improper adjustment may require extensive work by a qualified technician to restore the telephone to normal operation; if the telephone does not operate normally by following the operating instructions.
15. Never install telephone wiring during a lightning storm.
16. Never install telephone jacks in wet locations unless the jack is specifically designed for wet locations.
17. Never touch uninsulated telephone wires or terminals unless the telephone line has been disconnected at the network interface.

IMPORTANT SAFETY INSTRUCTIONS

18. Use caution when installing or modifying telephone lines.
19. This product should be operated only from the type of power source indicated on the marking label. If you are not sure of the type of power supply to your home, consult your local power company.
20. Do not attempt to open the AC adapter. There are potentially dangerous voltages inside, and there are no serviceable parts.
21. Discontinue use of product and contact Clarity if the product overheats, has a damaged cord or plug, if the product has been dropped or damaged or if the product has come into contact with liquids.
22. Use only the AC adapter provided with this product or a replacement AC adapter provided by Clarity.
23. This phone amplifies sound to loud volumes. To prevent hearing damage, all users of the phone should be informed of the high volume capability of the phone and children should only use the phone when supervised by an adult.
24. Exposure to high volume sound levels or excessive sound pressure may cause temporary or permanent damage to your hearing. Although there is no single volume setting that is appropriate for everyone, you should always use your telephone with the volume set at moderate levels

IMPORTANT SAFETY INSTRUCTIONS

and avoid prolonged exposure to high volume sound levels. The louder the volume, the less time is required before your hearing could be affected. If you experience hearing discomfort, you should have your hearing checked by a doctor. To protect your hearing, you should:

- A) Set the volume control in a low position and gradually increase the volume as needed. Before pressing the BOOST button, reduce the volume to the lowest level. Use the phone on the lowest volume setting as possible.
 - B) Limit the amount of time you use the telephone at high volume levels.
25. If you experience a skin irritation after using this product, discontinue use and contact Clarity.

SAVE THESE INSTRUCTIONS

IMPORTANT SAFETY INSTRUCTIONS

BATTERY SAFETY INSTRUCTIONS

WARNING: Dispose of used batteries according to the instructions.

1. Do not dispose of the battery in a fire as it may explode. Check with local codes for possible special disposal instructions.
2. Do not open or mutilate the battery. Released electrolyte is corrosive and may cause damage to the eyes and skin. It may be toxic if swallowed.
3. Exercise care in handling batteries in order not to short the battery with conducting materials such as rings, bracelets and keys. The battery or conduction material may over-heat and cause burns.
4. Remove batteries when they are discharged and when the equipment will not be used for an extended period of time. Dispose of batteries according to local environmental laws.
5. Do not disassemble, heat, crush, deform or puncture batteries.
6. Do not attempt to charge non-rechargeable batteries.
7. Keep batteries out of the reach of children.

PACKAGING CONTENTS LOCATION

Package contains the following items:

- Answering Machine base station
- AC power adapter for Answering Machine base station
- Telephone line cord for Answering Machine base station
- Cordless Handset
- (2) Rechargeable batteries for cordless handset
- User Manual
- Warranty/FCC Requirements booklet

Installation Location

For maximum coverage and reduce the interference, here are some guidelines you should consider when you place the base unit,

- Place it at a convenient, high, and central location with no obstructions between the handset and base unit in an indoor environment.
- Place it away from electronic appliances such as televisions, microwave ovens, radios, personal computers, wireless devices or other cordless phones.
- Avoid facing radio frequency transmitters, such as external antennas of mobile phone cell stations.
- Avoid plugging it into the same circuit as other major household electrical appliances because of the potential for interference. Try moving the appliance or the base unit to another power outlet.

CONNECTING THE BASE

If the reception for a base unit location is not satisfactory, move it to another location for better reception. Depending on the surrounding conditions as well as spatial and structural factors, the range may be reduced. The range indoors is normally less than outdoors.

CONNECTING THE ANSWERING MACHINE BASE STATION

- 1 – Plug the telephone line into the jack located on the back of the base station. Plug the other end of the telephone line into a phone wall outlet.
- 2 – Plug the power supply cord into the jack located on the back of the base station. Plug the other end of power supply line cord into an electrical outlet.

Always use the cables provided in the box.

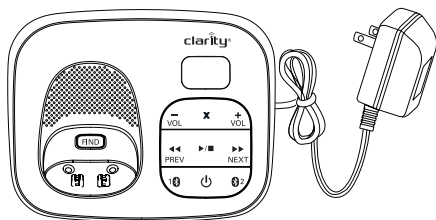

CONNECTING THE BASE

WARNINGS: Use only the power adapter provided for the base station.

Always use the cables provided in the box, others may not be compatible.

NOTE: The base unit needs mains power for normal operation, and the cordless handset will not work without it.

- Use only the power adapters supplied with this product.
- Even if you do not subscribe to any conventional telephone service, you can pair a Bluetooth enabled cell phone to your telephone base (see Bluetooth), and use the cell line alone without plugging in a telephone line cord.
- If you subscribe to telephone service from a cable company or a VoIP service provider, contact your cable/VoIP service provider for more information.

INSTALLING THE BATTERIES

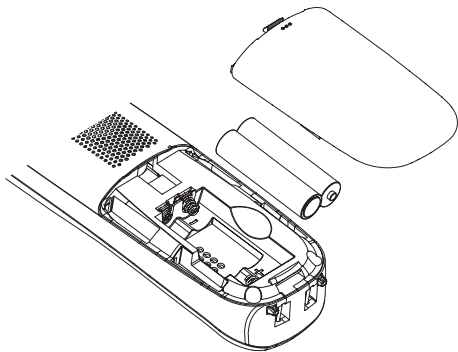

Note:

- Use only the batteries provided or equivalent.
- If the handset will not be used for a long time, disconnect and remove the batteries to prevent possible leakage.
- To purchase replacement batteries, go to any store that sells batteries: **NiMH AAA 1.2V 500mAh.**

Charge the batteries

Once you have installed the batteries, the screen indicates the battery status.

Note:

- For best performance, keep the handset in the telephone base or charger when not in use.
- The batteries are fully charged after 16 hours of continuous charging.

BATTERY DETAILS

Battery indicators	Battery status	Action
The screen is blank, or shows Put in charger and the battery symbol flashes.	The battery has no charge or very little charge. The handset cannot be used.	Charge without interruption (at least 30 minutes)
The screen shows Low Battery and the battery symbol flashes.	The battery has enough charge to be used for a short time.	Charge without interruption (at least 30 minutes)
The screen shows Handset X.	The battery is charged.	To keep the battery charged, place it in the telephone base or charger when not in use.

Note: If you place the handset in the telephone base or charger without inserting the batteries, the screen displays No battery.

BATTERY DETAILS

When it is fully charged, you can expect the following performance:

Operations	Operating Time
While in handset use (talking*)	Seven hours
While in speakerphone mode (talking*)	Three hours
While not in use (stand-by**)	Five days

*Operating times vary depending on your actual use and the age of the battery

**Handset is not charging or in use.

IMPORTANT:

- Rechargeable batteries: Exercise care in handling batteries in order not to create a short circuit with conducting material such as rings, bracelets, and keys. The battery or conductor may overheat and cause harm. Observe proper polarity between the battery and the battery charger.
- Nickel-metal hydride rechargeable batteries: Dispose of these batteries in a safe manner. Do not burn or puncture the battery. Like other batteries of this type, if burned or punctured, they could release caustic material which could cause injury.

BEFORE USE

After you install your telephone or power returns following a power outage, the handset will prompt you to set the date and time, and the answering system through voice guide.

If you choose to set up the date and time, and the answering system at a later stage, you can do it manually.

Set date and time

1. Use the dialing keys (0-9) to enter the month, date, and year, and then press **SELECT**.
2. Use the dialing keys (0-9) to enter the hour and minute.
3. Press the **UP** or **DOWN** arrow keys to choose AM or PM, and then press **SELECT** to save.
 - To skip setting, press the **Red phone** button.

After the setting for the date and time, the handset will display **Voice guide to...** and set up **Ans sys?** alternatively.

Set answering system through voice guide

This feature assists you to do the basic setup of the answering system. You can follow the voice guide to record your own announcement, set the number of rings and the message alert tone.

BEFORE USE

1. Press **MENU** to start the voice guide for the answering system setup. You hear the voice prompt *“Hello! This voice guide will assist you with the basic setup of your answering system.”*
2. Setup your answering system by inputting the designated numbers as instructed in the voice guide.
 - To skip setting, press the **Red phone** button.

IMPORTANT:

Check for a dial tone by pressing **Green phone/Flash** button. If you hear a dial tone, the installation is successful.

If you do not hear a dial tone:

- Make sure the installation procedures described above are properly done.
- It may be a wiring problem. If you have changed your telephone service to digital service from a cable company or a VoIP service provider, the telephone line may need to be rewired to allow all existing telephone jacks to work. Contact your cable/VoIP service provider for more information.

BEFORE USE

Operating range

This cordless telephone operates with the maximum power allowed by the Federal Communications Commission (FCC). Even so, this handset and telephone base can communicate over only a certain distance- which can vary with the locations of the telephone base and handset, the weather, and the layout of your home or office. When the handset is out of range, the handset displays **Out of range or** and **no pwr at base** alternately.

If there is a call while the handset is out of range, it may not ring, or if it does ring, the call may not connect well when you press the **Green phone/Flash** button or **Cell phone** button. Move closer to the telephone base, and then press the **Green phone/Flash** button or **Cell phone** button to answer the call. If the handset moves out of range during a telephone conversation, there may be interference. To improve reception, move closer to the telephone base.

GETTING TO KNOW YOUR HANDSET

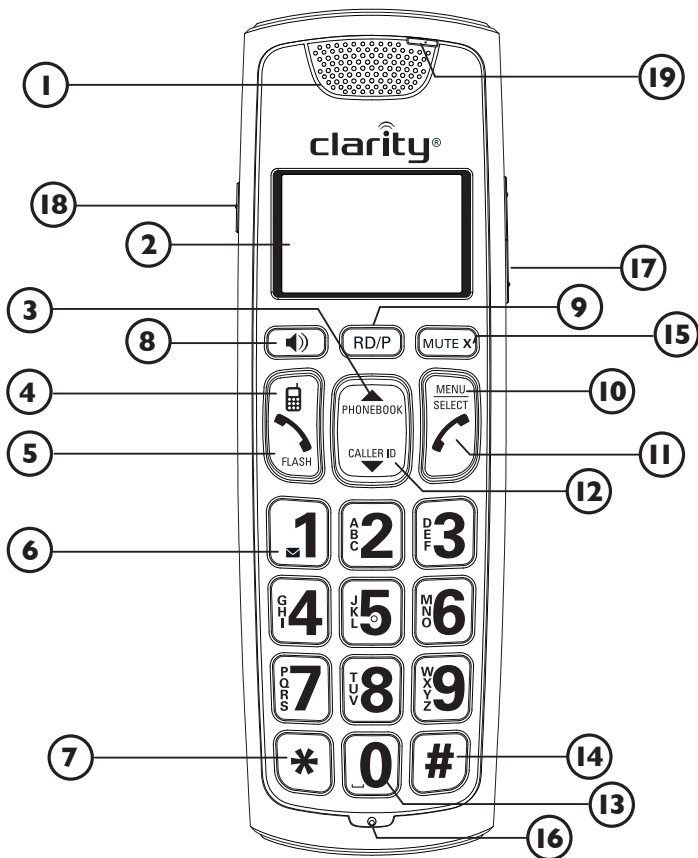

GETTING TO KNOW YOUR HANDSET

1	Handset earpiece
2	LCD Display
3	UP Arrow key/Phonebook <ul style="list-style-type: none">• Review the phone book when the phone is not in use.• Increase the listening volume during a call or message playback.• Scroll up while in a menu, or in the phonebook, caller ID log, or redia list.• Move the cursor to the right when entering numbers or names.
4	Cell phone button <ul style="list-style-type: none">• Make or answer a cell call.• Answer an incoming cell call when you hear a call waiting alert.
5	Green Phone/Flash button <ul style="list-style-type: none">• Make or answer a home call.• Answer an incoming home call when you hear a call waiting alert.

GETTING TO KNOW YOUR HANDSET

6	I key/Voicemail <ul style="list-style-type: none">• Press repeatedly to add or remove “I” in front of the caller ID log entry before dialing or saving it to the phonebook.• Press and hold to set or dial your voicemail number.
7	*/Tone key <ul style="list-style-type: none">• While you have set the dial mode to pulse and on a call, press to switch to tone dialing temporarily.
8	Speakerphone button <ul style="list-style-type: none">• Make or answer a call using the handset speakerphone.• During a call, press to switch between the speakerphone and the handset.
9	Redial/Pause (RD/P) <ul style="list-style-type: none">• Press repeatedly to review the redial list.• Press and hold to insert a dialing pause while entering a number.
10	Menu/Select <ul style="list-style-type: none">• Show the menu.• While in a menu, press to select an item, or save an entry or setting.

GETTING TO KNOW YOUR HANDSET

11	Red Phone button <ul style="list-style-type: none">• Hang up a call.• Silence the ringer temporarily while the handset is ringing.• Press and hold to erase the missed call indicator while the phone is not in use.• Press to return to the previous menu, or press and hold to return to idle mode, without making changes.
12	Down Arrow key/CID <ul style="list-style-type: none">• Review the caller ID log when the phone is not in use.• Decrease the listening volume during a call or message playback.• Scroll DOWN while in a menu, or in the phonebook, caller ID log, or redial list.• Move the cursor to the left when entering numbers or names.
13	0 key <ul style="list-style-type: none">• Press to add a space when entering names.

GETTING TO KNOW YOUR HANDSET

14	# key <ul style="list-style-type: none">• Press repeatedly to show other dialing options when reviewing a caller ID log entry.
15	Mute/X <ul style="list-style-type: none">• Mute the microphone during a call.• Delete digits or characters while using the dialing keys.• Silence the ringer temporarily while the handset is ringing.
16	Microphone
17	Volume Up and Down Arrows <ul style="list-style-type: none">• These buttons can increase and decrease the volume during a call.
18	Boost Button <ul style="list-style-type: none">• This button gives a boost of volume. This button in conjunction with the Volume UP Arrow key, can make the phone amplified up to 40 db.
19	Visual Indicator <ul style="list-style-type: none">• This light will flash for an incoming call and will also be on during a call if Auto Boost activated.

Note: *Idle mode* is when the phone is on but it is not being used.

GETTING TO KNOW YOUR BASE

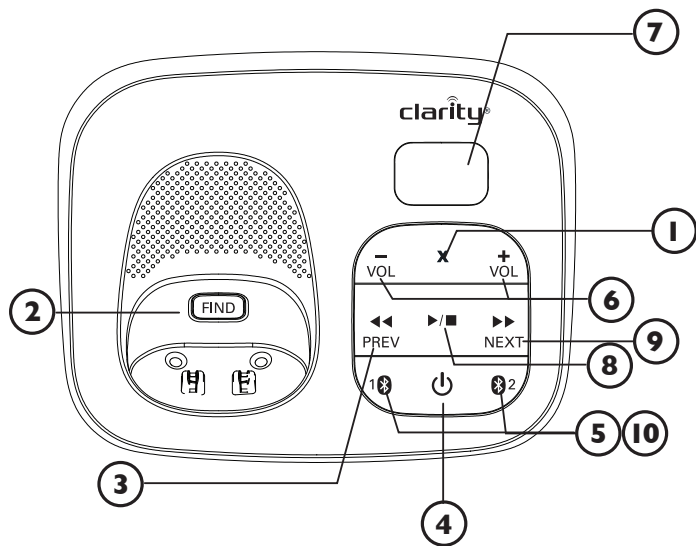

GETTING TO KNOW YOUR BASE

1	X <ul style="list-style-type: none">• Delete the playing message.• Press twice to delete all previously reviewed messages when the phone is not in use.
2	Find <ul style="list-style-type: none">• Press to page all system handsets.
3	Prev <ul style="list-style-type: none">• Press to repeat a message.• Press twice to play the previous message.
4	Power button <ul style="list-style-type: none">• Turn the answering system on or off
5	Bluetooth 1 and Bluetooth 2/Headset <ul style="list-style-type: none">• Press to connect the paired Bluetooth device.• Press and hold to add or replace a Bluetooth device.
6	-Vol/+Vol <ul style="list-style-type: none">• Adjust the volume during message playback.• Adjust the telephone base ringer volume when the phone is not in use.

GETTING TO KNOW YOUR BASE

7	Message window <ul style="list-style-type: none">• Shows the number of messages, and other information of the answering system or telephone base.
8	Play/Stop <ul style="list-style-type: none">• Play messages.• Stop playing messages.
9	Next <ul style="list-style-type: none">• Skip to the next message.
10	Bluetooth 1 and Bluetooth 2/Headset Lights <ul style="list-style-type: none">• On when the telephone base is paired and connected with a Bluetooth device.• Flashes when the telephone base is in discoverable mode

About cordless telephones

- **Privacy:** The same features that make a cordless telephone convenient create some limitations. Telephone calls are transmitted between the telephone base and the cordless handset by radio waves, so there is a possibility that the cordless telephone conversations could be intercepted by radio receiving equipment within range of the cordless handset. For this

GETTING TO KNOW YOUR BASE

reason, you should not think of cordless telephone conversations as being as private as those on corded telephones.

- **Electrical power:** The telephone base of this cordless telephone must be connected to a working electrical outlet. The electrical outlet should not be controlled by a wall switch. Calls cannot be made from the cordless handset if the telephone base is unplugged, switched off or if the electrical power is interrupted.
- **Potential TV interference:** Some cordless telephones operate at frequencies that may cause interference to televisions and VCRs. To minimize or prevent such interference, do not place the telephone base of the cordless telephone near or on top of a TV or VCR. If interference is experienced, moving the cordless telephone farther away from the TV or VCR often reduces or eliminates the interference.

BLUETOOTH FUNCTIONS

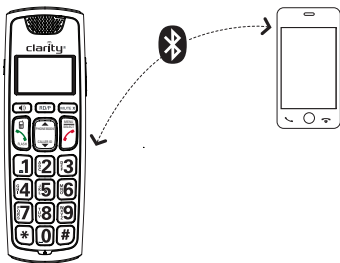

Pair and connect your Bluetooth enabled cell phone

To use a Bluetooth enabled cell phone with your BT914, you must first pair and connect your Bluetooth cell phone(s) with the telephone base. All BT914 handsets can be used to make or answer calls on the cell line. Your cell line is the telephone line associated with your cell phone service.

Bluetooth wireless technology operates within a short range (a maximum of approximately 30 feet). When you pair a Bluetooth cell phone to the telephone base, place your Bluetooth cell phone closer to the telephone base to maintain sufficient signal strength. For optimal performance, keep your cell phone within 15 feet of the telephone base while using the cell line.

1. Choose a slot to pair the cell phone. Press and hold Bluetooth 1 or Bluetooth 2/Headset on the telephone base

BLUETOOTH FUNCTIONS

until you hear a confirmation tone, and the Bluetooth 1 or Bluetooth 2/Headset light flashes.

2. Turn on the Bluetooth feature of your cell phone. Once your cell phone finds your Clarity Phone (Clarity BT914), press the appropriate key on your cell phone to continue the pairing process.
 - Your cell phone may prompt you to enter the PIN of the telephone base. The default PIN of the telephone base is **0000**.

When the cell phone is connected to the telephone base, the corresponding status icon (Bluetooth 1 or Bluetooth 2) displays. The corresponding device light (Bluetooth 1 or Bluetooth 2/Headset) turns on.

If the pairing fails, turn off the Bluetooth feature on your cell phone and on the BT914 by pressing Bluetooth 1 or Bluetooth 2/Headset. Then repeat the steps above to pair and connect again. In some cases, it may take you a few attempts to complete the pairing process.

Pair and connect your Bluetooth enabled headset

1. Press **MENU** on the phone when it is not in use.
2. Press the **UP** or **DOWN** arrow keys to scroll to **Bluetooth**, and then press **SELECT**.
3. Press the **UP** or **DOWN** arrow keys to scroll to **Add BT headset**, and then press **SELECT**. The screen displays

BLUETOOTH FUNCTIONS

Search headset...

4. Set your headset to discoverable mode. Once your handset finds your headset, press **SELECT**.
 - Enter the PIN of your headset if required. The PIN for most Bluetooth devices is 0000 (refer to the user's manual of your headset), and then press **SELECT**.

When the headset is successfully paired and connected to the telephone base, the Bluetooth 2 icon displays. The Bluetooth 2/Headset light turns on.

Download contacts from your Bluetooth cell phone

1. Press **MENU** when the phone is not in use.
2. Scroll to **Bluetooth**, and then press **SELECT**.
3. Scroll to **Download PB**, and then press **SELECT**.
4. Scroll to select the desired cell phone, and then press **SELECT**.

Note:

- For certain cell phones, you may need to press a key on your cell phone to confirm the phonebook downloaded.
- The performance of the phonebook download feature depends on the compatibility of your Bluetooth cell phone. Refer to the user's manual of your cell phone for more

BLUETOOTH FUNCTIONS

information about how that device uses Bluetooth connectivity.

- Certain cell phones do not support SIM card download. If this is the case, transfer the contacts from your SIM card to your cell phone memory first. Then download from your cell phone memory. For more information on how to transfer contacts from your SIM card to your cell phone memory, see the user's manual of your cell phone.
1. Press **MENU** when the phone is not in use.
 2. Press the **UP** or **DOWN** arrow keys until the screen displays the desired feature menu.
 3. Press **SELECT** to enter that menu.
- To return to the previous menu, press the **Red phone** button.
 - To return to the idle mode, press and hold the **Red phone** button.

HANDSET MENU

Telephone settings

Default settings are indicated by asterisks (*).

Settings menu	Description	Options
LCD language	Set the screen display language.	English*, Français, Español
Voicemail #	Save the speed dial voicemail number to key 1.	Voicemail # _
Clr voicemail	Turn off the voicemail indicators (see the note below).	N/A
Key tone	Turn an audible beep on or off whenever a key is pressed.	On* Off
Home area code	Enter your home area code if you dial only seven digits for local calls.	Home area code ---
Dial mode	Set the telephone to be touch-tone or pulse dialing.	Touch-tone* Pulse

HANDSET MENU

Equalizer	Set the best audio tone for your hearing needs.	Natural*, Treble, Bass
Auto Boost	Auto boost keeps the boost button activated at all times. This eliminates the need to press the “Boost” button for each call.	Off* On

Note:

Use the **Clr voicemail** feature when the telephone indicates there is a new voicemail but there is none. For example, when you have accessed your voicemail while away from home. The Clr voicemail feature only turns off the indicators; it does not delete your voicemail messages. As long as you have new voicemail messages, your telephone service provider continues to send the signal that turns on the indicators.

TELEPHONE OPERATIONS

The following are some of the telephone features you may wish to set.

Ringer volume (handset)

You can adjust the ringer volume level, or turn the ringer off.

1. Press **MENU** when the handset is not in use.
2. Scroll to **Ringers**, and then press **SELECT**.
3. Scroll to choose **Home volume** or **Cell volume**, and then press **SELECT**.
4. Press the **UP** or **DOWN** arrow keys to adjust the volume, and then press **SELECT** to save.

Note: if the handset ringer volume is set to off, that handset is silenced for all incoming calls except paging tone.

Ringer tone (handset)

You can choose from ten different ringer tones.

1. Press **MENU** when the handset is not in use.
2. Scroll to **Ringers**, and then press **SELECT**.
3. Scroll to choose **Home ringtone** or **Cell ringtone**, and then press **SELECT**.
4. Press the **UP** or **DOWN** arrow keys to sample each ringer tone, and then press **SELECT** to save.

Note: if you turn off the ringer volume, you will not hear ringer tone samples.

TELEPHONE OPERATIONS

Set date and time

If you subscribe to caller ID service, the day, month, and time are set automatically with each incoming call. You can also set the date and time manually.

1. Press **MENU** when the handset is not in use.
2. Scroll to **Set date/time**, and then press **SELECT**.
3. Use the dialing keys (0-9) to enter the month, date, and year, and then press **SELECT**.
4. Use the dialing keys (0-9) to enter the hour and minute.
5. Press the **UP** or **DOWN** arrow keys to choose **AM** or **PM**, and then press **SELECT** to save.

Make a home call

- Press the **Green Phone/Flash button** or the **Speakerphone** button, and then dial the telephone number.

Make a cell call

- Press the **Cell phone** button. Enter the telephone number and then press the **Cell phone** button to dial.
- OR-
- Enter the telephone number and then press the **Cell phone** button to dial.

TELEPHONE OPERATIONS

Note:

- After first pressing the **Cell phone** button, you may need to choose a cell device. Scroll to select the desired cell device when necessary, and then press **SELECT**.
- While using the cell line, place your cell phone closer to the telephone base, and make sure that there are no physical obstacles between the telephone base and the cell phone, such as large furniture or thick walls.

Answer a home/cell call

- Press the **Green Phone, Cell phone, speakerphone** button, or any dialing key.

End a home/cell call

- Press the **Red Phone** button, or put the handset to the telephone base or charger.

Speakerphone

- During a call, press the **Speakerphone** button to switch between speakerphone and normal handset use.

Volume

- During a call, press the **Volume UP** or **DOWN** arrow keys to adjust the listening volume for amplification of up to 40dB.

TELEPHONE OPERATIONS

Note:

The handset earpiece volume setting and speakerphone volume setting are independent.

Boost

- During a call, press the **Boost** button to give added amplification of the listening volume. The handset displays **Audio Boost**. Press the **Boost** button again to turn the Boost off.

**WARNING: VOLUME
MAY BE LOUD!**

Mute

The mute function allows you to hear the other party but the other party cannot hear you.

1. During a call, press **MUTE**. The handset displays **Muted**.
2. Press **MUTE** again to resume the conversation. The handset displays **Microphone on**.

Call waiting

When you subscribe to call waiting service from your telephone service provider, you hear an alert tone if there is an incoming call while you are on another call.

Call waiting on the home line:

- Press **FLASH** to put the current call on hold and take the new call.

TELEPHONE OPERATIONS

- Press **FLASH** to switch back and forth between calls.

Call waiting on the cell line:

- Press the **Cell phone** button to put the current call on hold and take the new call.
- Press the **Cell phone** button to switch back and forth between calls.

Temporary ringer silencing

When the telephone is ringing, you can temporarily silence the ringer of the handset without disconnecting the call. The next call rings normally at the present volume. The base will still ring unless you have turned the base ringer off.

- Press the **Red Phone** button or **MUTE** on the handset. The handset displays a bell with a line through it.

Note: The base will still ring even if you temporarily silence the handset. The base will not ring if you turned the base ringer off.

Temporary tone dialing

If you have pulse (rotary) service only, you can switch from pulse to dialing temporarily during a call.

1. During a call, press *.
2. Use the dialing keys to enter the relevant number. The telephone sends touch-tone signals. It automatically returns to pulse dialing mode after you end the call.

TELEPHONE OPERATIONS

Find handset

Use this feature to find all system handsets.

To start paging:

- Press **FIND** on the telephone base. All idle handsets ring and display ****Paging****.

To end paging:

- Press **FIND** again on the telephone base.

-OR-

- Press the **Green Phone** button, **Cell phone** Button, **Speakerphone** button, **Red Phone** button, or any dialing key on the handset.

-OR-

- Place handset in the telephone base or charger.

Note:

Do not press and hold **FIND** for more than four seconds. It may lead to handset deregistration.

Redial list

Each handset stores the last 10 telephone numbers dialed. When there are already 10 entries, the oldest entry is deleted to make room for the new entry.

To review and dial a number from the redial list:

1. Press **REDIAL** when the handset is not in use.

TELEPHONE OPERATIONS

2. Press the **UP** or **DOWN** arrow keys or **REDIAL** repeatedly until the desired entry displays.
3. Press the **Green phone** button, **Cell phone** button or **Speakerphone** button to dial.

To delete a redial entry:

When the desired redial entry displays, press **MUTE X**.

Join a call in progress

You can use up to two system handsets at a time on a home line call. You can buy additional extension handsets (BT914HS) for this telephone base. You can register up to five handsets to the telephone base.

- When a handset is on a home call, press the **Green phone** button or **Speakerphone** button on another handset to join the call.
- Press the **Red phone** button to exit the call. The call continues until all handsets hang up.

Intercom

Use the intercom feature for conversations between two devices.

1. Press **MENU** on your handset when not in use.
2. Press the **UP** or **DOWN** arrow keys to scroll to Intercom, and then press **SELECT**. Use the dialing keys to enter a destination device number.

TELEPHONE OPERATIONS

3. To answer the intercom call, press the **Green phone** button, **Cell phone** button, **Speakerphone** button or any dialing key on the destination handset.
4. To end the intercom call, press the **Red phone** button or place the handset back in the telephone base or charger.

Transfer a call

While on an outside call, you can use the intercom feature to transfer the call from one handset to another.

1. Press **MENU** on your handset during a call.
2. Press the **UP** or **DOWN** arrow keys to scroll to Intercom, and then press **SELECT**. The current call is put on hold. Use the dialing keys to enter a destination device number.
3. To answer the intercom call, press the **Green phone** button, **Cell phone** button, **Speakerphone** button, or any dialing key on the destination handset. You can now have a private conversation before transferring the call.
4. To transfer the call, press the **Red phone** button on the initiating handset or place the initiating handset back in the telephone base or charger.
5. To end the call, press the **Red phone** button on the destination handset or place the destination handset back in the telephone base or charger.

TELEPHONE OPERATIONS

Answer an incoming call during an intercom call

If you receive an incoming call during an intercom call, there is an alert tone.

- To answer a home call, press the **Green phone** button. The intercom call ends automatically.
- To end the intercom call without answering the outside call, press the **Red phone** button. The intercom call ends and the telephone continues to ring.
- To answer a cell call, press the **Red phone** button to end the intercom call. The telephone continues to ring. Then press the **Cell phone** button.

Phonebook

The phonebook can store up to 1000 entries and are shared by all system handsets.

To add a phonebook entry:

1. Press **MENU** when the phone is not in use.
2. Scroll to **Phonebook** and then press **SELECT**.
3. Press **SELECT** again to choose Add new entry.
4. Enter the number.
 - Use the dialing keys to enter the number (up to 30 digits).
5. Press **SELECT** to move to the name.

TELEPHONE OPERATIONS

6. Use the dialing keys to enter the name (up to 15 characters). Additional key presses show other characters of that particular key.
7. Press **SELECT** to save.

While entering numbers and names, you can:

- Press **MUTE X** to erase a digit or character.
- Press and hold **MUTE X** to erase the entire entry.
- Press the **UP** or **DOWN** arrow keys to move the cursor to the left or right.
- Press and hold **RD/P** to insert a dialing pause (for entering phone numbers only).
- Press 0 to add a space (for entering names only).
- Press * to add * or # to add # (for entering phone numbers only).
- Press | to enter punctuation (for entering names only).

To review and dial from the phonebook:

Entries are sorted alphabetically.

1. Press the **UP** arrow key when the phone is not in use.
2. Scroll to browse through the phonebook, or use the dialing keys to start a name search (you can enter up to 3 characters for the search).

TELEPHONE OPERATIONS

3. When the desired entry appears, press the **Green phone** button, **Cell phone** button or **Speakerphone** to dial.

To edit a phonebook entry:

1. When the desired entry displays, press **MENU**.
2. Use the dialing keys to edit the number, and then press **SELECT**.
3. Use the dialing keys to edit the name, and then press **SELECT** to save.

To delete a phonebook entry:

1. When the desired entry displays, press **MUTE X**.
2. When the screen displays **Delete entry?**, press **SELECT**.

To delete all phonebook entries:

1. Press **MENU** when the phone is not in use.
2. Scroll to **Phonebook**, and then press **SELECT**.
3. Scroll to **Delete all**, and then press **SELECT**.
4. When the screen displays **Delete all?**, press **SELECT**.

Caller ID

This product supports caller ID services provided by most telephone service providers. Depending on your service

TELEPHONE OPERATIONS

subscription, you may see the caller's name, number, date and time of calls that are sent by your telephone service provider after the first or second ring.

Caller ID log

The caller ID log stores up to 50 entries. If you answer a call before the caller information appears, it will not be saved in the caller ID log.

- The handset displays **XX missed calls** when there are calls that have not been reviewed in the caller ID log.
- If you want to erase the missed call indicator, press and hold the **Red phone** button on the idle handset.

To review and dial a number in the caller ID log:

1. Press the **DOWN** arrow key when the phone is not in use.
2. Scroll to browse through the caller ID log. When the desired entry appears:
 - Press # repeatedly to show different dialing options
 - Press I repeatedly if you need to add or remove I in front of the phone number.
3. Press the **Green phone** button, **Cell** phone button or **Speakerphone** button to dial the displayed number.

TELEPHONE OPERATIONS

To save a caller ID log entry to the phonebook:

1. When the desired caller ID log entry displays, press **MENU**.
2. Scroll to **To Phonebook** then press **SELECT**.
3. Use the dialing keys to modify the number, and then press **SELECT**.
4. Use the dialing keys to modify the name, and then press **SELECT** to save.

To delete a caller ID log entry:

- When the desired caller ID long entry displays, press **MUTE X**.

To delete all caller ID log entries:

- Press **MENU** when the phone is not in use. Scroll to **Caller ID log** and then press **SELECT**. Scroll to **Delete all** and then press **SELECT** twice.

About answering system and voicemail service

For message recording, your telephone has a built-in answering system, and it also supports voicemail service offered by your telephone service provider (subscription is required, and fees may apply).

TELEPHONE OPERATIONS

The main differences between them are as follows:

Category	Built-in answering system	Voicemail from telephone service
Storage	Messages are stored in the telephone base.	Messages are stored in a server or system provided by your telephone service.
Maximum number of messages	This depends on the design of telephone base. You cannot change the maximum number of messages that can be recorded.	This may vary with your telephone service plan (fee may apply). Contact your telephone service provider for more information.
Method to retrieve messages	Usually, there are two ways to retrieve messages: <ul style="list-style-type: none">• Press a button on the telephone base;or• Access remotely with an access code	To retrieve messages, you need an access number and/or a secret code provided by your service provider.

TELEPHONE OPERATIONS

Set your built-in answering system

Your answering system has various features, read below for the basic settings. Default settings are indicated by asterisks (*).

Menu	Description	Options
Announcement	Play, record, or delete an announcement for incoming calls.	Play [2]; Del [3]; Rec [7]
Delete all old	Delete all old (reviewed) messages.	N/A
Record memo	Record a memo as reminders for yourself or others using the answering system.	N/A
Answer on/off	Turn on or off the answering system.	On Off
Voice guide	Follow audio instructions to set basic features.	N/A

TELEPHONE OPERATIONS

Ans sys setup		
	Change the settings of call screening, number of rings, remote code, or message alert tone.	
<ul style="list-style-type: none"> • Call screening 	Set whether you hear the callers while they are leaving messages to you.	On* Off
<ul style="list-style-type: none"> • # of rings 	Set the number of times the telephone rings before the answering system answers.	3*;2;Toll saver; 6;5;4
<ul style="list-style-type: none"> • Remote code 	Set a two-digit security code to access the answering system remotely from any touch tone-telephone.	19*
<ul style="list-style-type: none"> • Msg alert tone 	Set to alert you when you have new messages.	On Off*
<ul style="list-style-type: none"> • Voice language 	The language the answering system speaks to you.	English* Français

TELEPHONE OPERATIONS

Record your own announcement with a handset

You can use the preset announcement to answer calls, or replace it with your own recorded announcement. It can be up to 90 seconds in length.

1. Press **MENU** when the phone is not in use.
2. Scroll to **Answering sys** and then press **SELECT** twice.
3. The handset announces, *“Announcement, press play or press record.”*
4. Press **7** to record. The handset announces, *“Record after the tone. Press STOP when you are done.”* After the tone, speak towards the handset microphone. Press **5** when done.

Set number of rings

You can set the answering system to answer an incoming call after 2, 3, 4, 5 or 6 rings; or toll saver. If you choose toll saver, the answering system answers a call after 2 rings when you have new messages, or after 4 rings when you have no new messages.

1. Press **MENU** when the phone is not in use.
2. Scroll to **Answering sys** then press **SELECT**.
3. Scroll to **Ans sys setup** then press **SELECT**.
4. Scroll to **# of rings** then press **SELECT**.
5. Press the **UP or DOWN** arrow key to choose **2, 3, 4, 5, 6** or **Toll saver** and then press **SELECT**.

TELEPHONE OPERATIONS

Message alert tone

When the message alert tone is set to on, and there is at least one new message, the telephone base beeps every 10 seconds. The message alert tone is preset to off.

1. Press **MENU** when the phone is not in use.
2. Scroll to **Answering sys** then press **SELECT**.
3. Scroll to **Ans sys setup** then press **SELECT**.
4. Scroll to **Msg alert tone** then press **SELECT**.
5. Press the **UP** or **DOWN** arrow key to choose **On** or **Off**.
6. Press **SELECT** to save and you hear a confirmation tone.

Use your built-in answering system

Turn the answering system on or off

The answering system must be turned on to answer and record messages.

- Press the **Power** button on the telephone base to turn the built-in answering system on or off.

Message playback at the telephone base

When you have received a message on your answering system, you will see that the message window on the telephone base flashes. Your handset displays **XX new messages**. To

TELEPHONE OPERATIONS

retrieve, press the **Play/Stop** button when the phone is not in use.

Note: It can record up to 99 messages, depending on the length of each message. Each message can be up to three minutes in length. The total recording time is approximately 25 minutes.

Options during playback:

- Press **-Vol** or **+Vol** to adjust the speaker volume.
- Press **Next** to skip to the next message.
- Press **Prev** to repeat the message currently playing. Press **Prev** twice to listen to the previous message.
- Press **X** to delete the message playing. The system advances to the next message.
- Press **Play/Stop** to stop.

Delete all old messages at the telephone base

Press **X** twice when the phone is not in use.

Call intercept

If you want to talk to the person whose message is being recorded, press the **Green phone** button or **Speakerphone** button on the handset.

TELEPHONE OPERATIONS

Use the built-in answering system and voicemail service

You can use your answering system and voicemail service together by setting your answering system to answer before voicemail service answers as described below. To learn how to program your voicemail settings, contact your telephone service provider.

If you are on a call, or if the answering system is busy recording a message and you receive another call, the second caller can leave a voicemail message.

Set your answering system to answer calls at least two rings earlier than your voicemail service is set to answer. For example, if your voicemail service answers after six rings, set your answering system to answer after four rings. Some voicemail service providers may program the delay before answering calls in seconds instead of rings. In this case, allow six seconds per ring when determining the appropriate setting.

Retrieve voicemail from telephone service

Retrieve voicemail

When you received a voicemail, the handset displays an envelope and New voicemail. To retrieve, you typically dial an access number provided by your telephone service provider, and

EXPAND YOUR SYSTEM

then enter a security code. Contact your telephone service provider for instructions on how to configure the voicemail settings and listen to messages.

Add and register a handset

You can add new cordless handsets (BT914HS) to your telephone system (purchased separately). Your telephone system supports a maximum of five handsets.

Additional handsets must be registered before they will operate.

Additional handsets registered to the telephone system are assigned numbers in the sequential order. Register each device with the base before use.

When first purchased and properly charged, each expansion handset shows **To register HS...** and **see manual** alternately. Charge the handset before registering it to the telephone base.

To register a handset:

- Place the new/non-registered handset in the telephone base. The handset shows **Registering...**
 - **Do not place the handset in the charger.**

EXPAND YOUR SYSTEM

The handset shows **Registered** and you hear a beep when the registration process completes. The registration process takes about 90 seconds to complete.

Deregister all devices

To replace a handset or reassign the designated handset number of a registered handset, you must deregister all devices and then individually register each handset.

To deregister all devices:

1. Press and hold **FIND** on the telephone base for about 10 seconds.
2. Immediately press **FIND** again.

All handsets show **To register HS...** and **... see manual** alternately when the deregistration process completes. The deregistration process takes about 10 seconds to complete.

FREQUENTLY ASKED QUESTIONS

If you have difficulty with your telephone, please try the suggestions below. If you cannot find the answer to your question, contact customer service by visiting our website at www.clarityproducts.com or calling 1 (800) 426-3738.

I cannot add and connect my cell phone or headset to the telephone base.

- Make sure you have cellular coverage and the Bluetooth function of your cell phone or headset is turned on. See the user's manual of your cell phone or headset for more information.
- Make sure that the telephone base is in discoverable mode.
- Carefully follow the pairing instructions. Make sure that your Bluetooth cell phone or headset is not connected to any other Bluetooth device, and is connected to the telephone base and active on the device list.
- Remove Clarity BT914 from your cell phone's hands free device history list (see the user's manual of your cell phone for more information).
- Turn off your cell phone or headset, and then turn it on again.
- For some cell phones, you must authorize Clarity BT914 device in your cell phone's Bluetooth feature. See the user's manual of your cell phone for more information.

FREQUENTLY ASKED QUESTIONS

- Most cell phones have the Bluetooth feature in the connection or setup menus. Please refer and then look for the Bluetooth menu in the settings or connection menu. In the Bluetooth menu, select the option to search for or add new devices.
- Reset the telephone base. Unplug the unit's electrical power. Wait for approximately 15 seconds, and then plug it back in. Repeat the above suggestions.

The PIN on the telephone base does not work.

- Make sure you enter the correct PIN. The default PIN is 0000.

Can the BT914 help the poor cell phone reception in my house?

- If your cell phone has poor reception in your home, the BT914 cannot improve the reception. However, if there is a location in your house with better reception, you can leave your cell phone at that location while you use the BT914 cell line. In order for this to work, the telephone base must be within 30 feet of the cell phone.

My telephone does not work at all.

- Make sure the batteries are installed and charged correctly. For optimum daily performance, return the handset to the telephone base or charger after use.

FREQUENTLY ASKED QUESTIONS

- Make sure the power adapter is securely plugged into an outlet not controlled by a wall switch.
- Make sure the telephone line cord is plugged firmly into the telephone base and the wall jack.
- Unplug the electrical power to the telephone base. Wait for approximately 15 seconds, and then plug it back in. Allow up to one minute for the cordless handset and telephone base to synchronize.
- Charge the batteries in the handset for up to 16 hours.
- If the batteries are completely depleted, charge the handset for at least 30 minutes before use.
- Remove the batteries and then install them again. If that still does not work, it may be necessary to purchase new batteries.
- Disconnect the telephone base from the telephone wall jack and plug in a working telephone. If the other telephone does not work, the problem is probably in the wiring or telephone service. Contact your telephone service provider.
- Make sure there is a dial tone before dialing. It is normal if the handset takes a second or two to synchronize with the telephone base before producing a dial tone. Wait an extra second before dialing.

FREQUENTLY ASKED QUESTIONS

- Eliminate any background noise. Mute the cordless handset before dialing, or dial from another room in your home with less background noise.
- If you have changed your telephone service to digital service from a cable company or a VoIP service provider, the telephone line may need to be rewired to allow all existing telephone jacks to work. Contact your service provider for more information.

The answering system does not answer after correct number of rings or does not record messages.

- Make sure the answering system is on. When the answering system is on, the handset shows **ANS ON**.
- If toll saver is selected, the number of rings changes to two when there are new messages.
- If the memory is full or the answering system is off, the answering system answers after 10 rings. In some cases, the answering system is affected by the ringing system used by the telephone service provider.
- Make sure the memory of the answering system is not full. When the answering machine memory is full, it does not record new messages until some old messages are deleted.
- If you subscribe to voicemail service, change the number of rings so that your answering machine system answers before your voicemail answers. To determine how many rings

FREQUENTLY ASKED QUESTIONS

activate your voicemail, contact your telephone service provider.

- If there is a fax machine connected to the same telephone line, try disconnecting the fax machine. If that solves the problem, consult your fax machine documentation for information on compatibility with answering systems.

The messages on the answering machine are incomplete.

- If a caller leaves a very long message, part of it may be lost when the answering system disconnects the call after the preset recording time.
- If the memory on the answering system becomes full during a message, the answering system stops recording and disconnects the call.
- If the caller's voice is very soft, the answering system may stop recording and disconnect the call.

I accidentally changed the LCD language to French or Spanish, and I don't know how to change it back to English.

- While the phone is not in use, press **MENU**, and then enter * 364 # to reset the LCD language to English.
- While the phone is on a call, press **MENU**, and then enter * 364 # to reset the LCD language to English. Then the call ends.

FREQUENTLY ASKED QUESTIONS

Common cure for electronic equipment.

- If the telephone is not responding normally, put the cordless handset in the telephone base. If this does not fix the problem, do the following (in the order listed):
 1. Disconnect the power to the telephone base.
 2. Disconnect the batteries on the cordless handset.
 3. Wait a few minutes before connecting power to the telephone base.
 4. Install the batteries again and place the cordless handset in the telephone base.
 5. Wait for the cordless handset to synchronize with the telephone base. Allow at least one minute for this to take place.

ECO mode

- This power conserving technology reduces power consumption for optimal battery performance.
- The ECO mode activates automatically whenever the handset is synchronized with the telephone base.
- The handset shows ECO when the ECO mode activates.

Energy-saving charging mode

When this mode is activated, all telephone functions, except the handset batteries charging, will be disabled.

ENERGY SAVING

To activate the energy-saving charging mode:

1. Unplug the telephone base power adapter from the power outlet. Make sure all handsets are plugged with charged batteries before proceeding.
2. While you press and hold FIND, plug the telephone base power adapter back to the power outlet.
3. After about 20 seconds, release the FIND button and then press it again within 2 seconds.

When the phone successfully enters the energy-saving mode, the handsets display To register HS... and ...see manual alternately.

When the phone fails to enter this mode, repeat Step 1 through 3 above. The telephone base will be powered up as normal if you fail to press FIND within 2 seconds in Step 3.

To deactivate the energy-saving charging mode:

1. Unplug the telephone base power adapter from the power outlet, and then plug it back in. Then the telephone base is powered up as normal.
2. Register your handsets back to the telephone base.

Note:

Remember that electrical appliances can cause serious injury if used when you are wet or standing in water. If the telephone base should fall into water, **DO NOT RETRIEVE IT**

GENERAL PRODUCT CARE

UNTIL YOU UNPLUG THE POWER CORD AND TELEPHONE LINE CORD FROM THE WALL. Then remove the telephone by the unplugged cords.

Taking care of your telephone

Your cordless telephone contains sophisticated electronic parts, so it must be treated with care.

Avoid rough treatment

Place the handset down gently. Save the original packing materials to protect your telephone if you ever need to ship it.

Avoid water

Your telephone can be damaged if it gets wet. Do not use the handset outdoors in the rain, or handle it with wet hands. Do not install the telephone base near a sink, bathtub or shower.

Electrical storms

Electrical storms can sometimes cause power surges harmful to electronic equipment. For your own safety, take caution when using electrical appliances during storms.

Cleaning your telephone

Your telephone has a durable plastic casing that should retain its luster for many years. Clean it only with a soft cloth slightly dampened with water or mild soap. Do not use excess water or cleaning solvents of any kind.

TECHNICAL DETAILS

Transmit frequency	DECT frequency: 1921.536-1928.448 MHz Bluetooth frequency: 2402.000-2480.000 MHz
Channels	DECT: 5 Bluetooth: 79
Nominal effective range	Maximum power allowed by FCC and IC. Actual operating range may vary according to environment conditions at the time of use.
Power requirements	Handset: Two 1.2V Ni-MH 500 mAh rechargeable batteries Telephone base: 6V DC @ 450mA Charger: 6V DC @ 450mA
Memory	Phonebook: 1000 memory locations (shared between home and cell lines); up to 30 digits and 15 characters Caller ID log: 50 memory locations; up to 24 digits and 15 characters

TECHNICAL DETAILS

Ordering additional handsets: Handset model number: **BT914HS™** (sold separately) Your system can accommodate up to 5 cordless handsets. To register additional handsets, follow directions in the **EXPANDING YOUR SYSTEM** section.

The *Bluetooth®* word mark and logos are owned by Bluetooth SIG, Inc. and any use of such marks by Clarity, a division of Plantronics, is under license. Clarity, a division of Plantronics, is a member of Bluetooth SIG, Inc. Other trademarks and trade names are those of their respective owners.

Specifications are subject to change without notice.



Clarity, a Division of Plantronics, Inc.
6131 Preservation Drive
Chattanooga, TN 37416

Tel: 800-426-3738 Fax: 800-325-8871
E-mail: claritycs@plantronics.com
Website: www.clarityproducts.com

©2014 Clarity, a Division of Plantronics, Inc. All rights reserved. Clarity, BT914, BT914HS, Smart for Seniors, are trademarks or registered trademarks of Plantronics, Inc.

Rev. E (9-14)
Printed in China